

# CORE-LUBE SYSTEM

## LINE OILER SYSTEM FOR WIRELINE TRUCKS & SKID UNITS

**The objective of this line oiler system is to penetrate the wireline with inhibitor leaving no mess.**

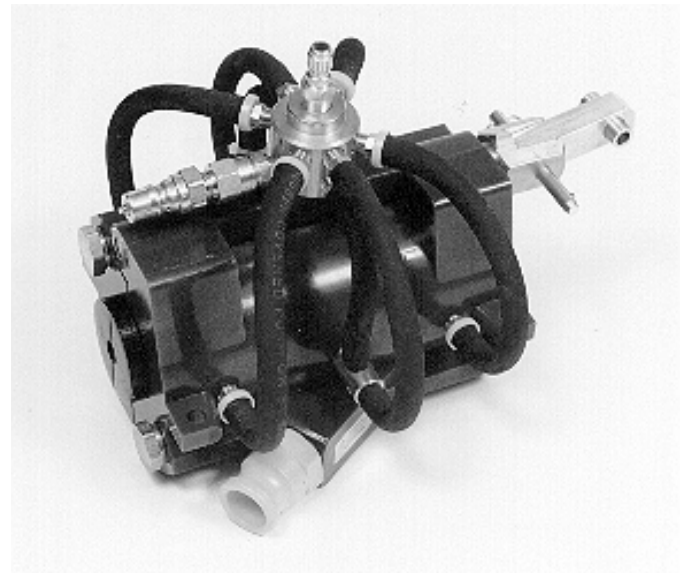
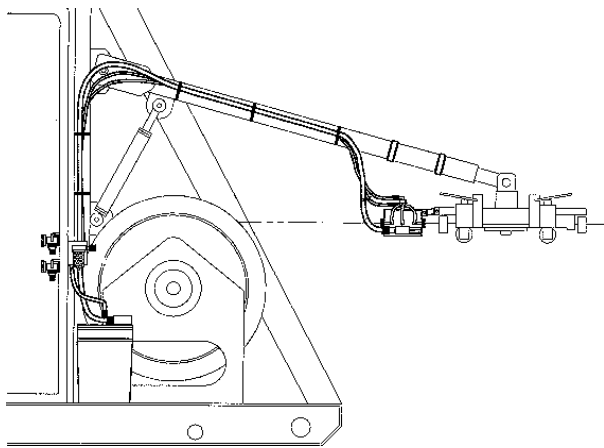

**Easy to operate.**

**Cleans the wireline.**

**Penetrates the outer & inner armors with inhibitor.**

**Eliminates accumulated oil under the drum.**

**Operates at varying line speeds.**

**Recycles the inhibitor.**



# CORE-LUBE SYSTEM

The Core-Lube System is operated by compressed air and uses its patented air seal design to operate cleanly and efficiently.

The Air Seal design sets this line oiler apart from all other oilers.

The ability to operate cleanly is achieved by the air seals removing excess oil from the line.

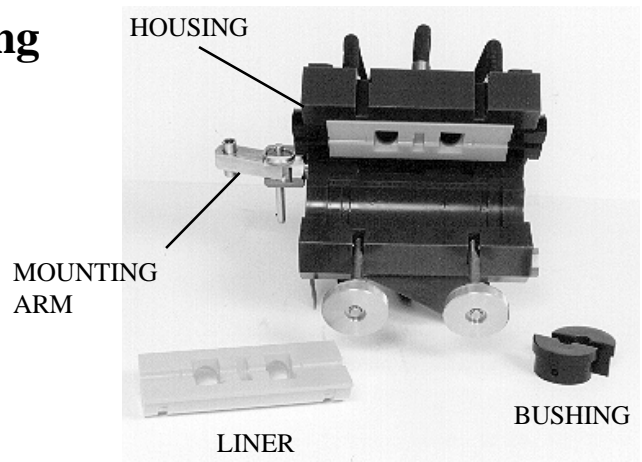
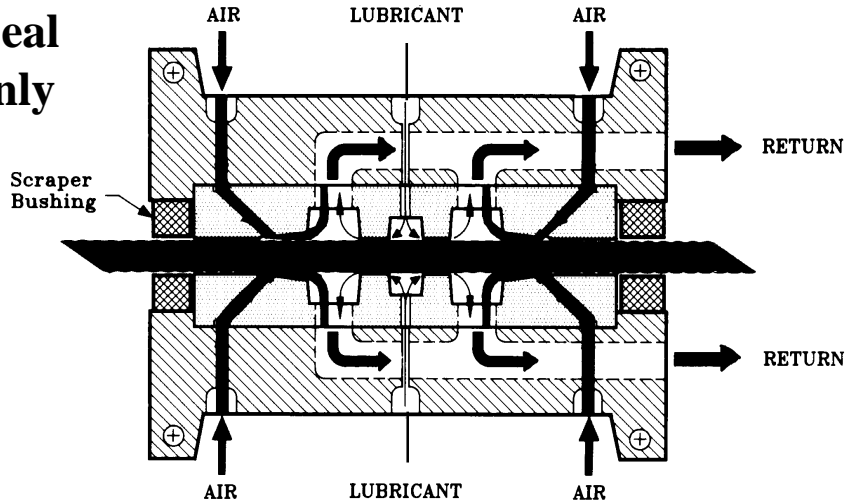

16" x 14" x 6"



The Core-Lube System comes complete as shown with mounting hardware, control panel, hoses, fittings, filters and container.

Housing dimensions: 10" x 8"  
Housing weight: 8 lbs.

**Mfg. CoreLube Equipment**

Phone: 403-529-9645

Fax: 403-527-1369

E-Mail: [corelube@telusplanet.net](mailto:corelube@telusplanet.net)