

CORELUBE

WIRE ROPE GREASE APPLICATOR

A-1600 APPLICATOR

The CORELUBE A-1600 ADVANTAGE

- Accommodates cables sizes from: 1/4" (12mm) --- 2 1/2" (64mm)
- The A-1600 housing unit is a high pressure grease injection collar that is designed to contain 3000 PSI. This is made possible by the solid machined aluminum housing, dual O-ring seals and high pressure cable seals. The cable seals are long in design for maximum efficiency and the small chambers exert a squeeze factor against the cable when under pressure. The higher the pressure the tighter the seal becomes around the cable.
- Removes the build up of old lubricant, dirt and grime.
- Displaces moisture from the cable.
- Forces new lubricant into the cable.
- Uniformly applies greases.
- Easy to operate.



**A-1600
HOUSING**

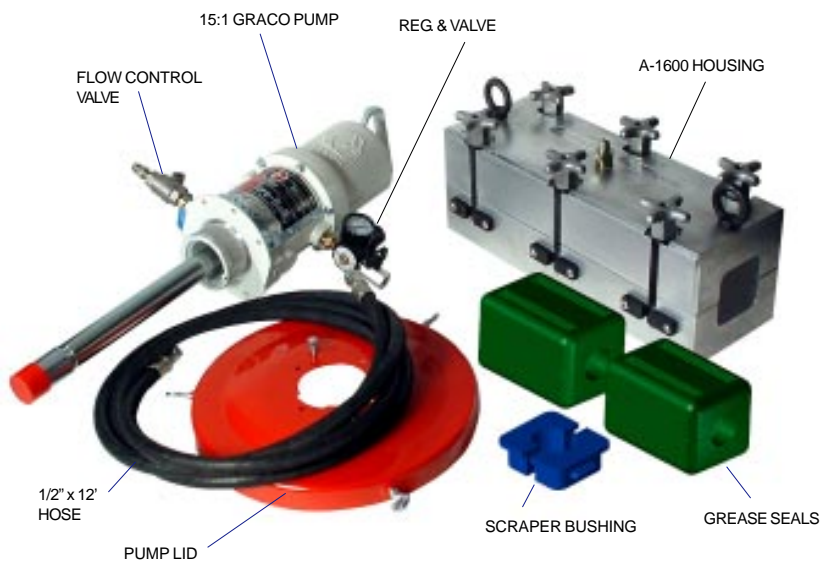

Other Grease Pump Package Available:

Fire-Ball 15:1 Pump Package Options Doc.
Fire-Ball 50:1 Pump Package Options Doc.



Fire-Ball 15:1



Fire-Ball 50:1

The Complete A-1600-LB1 Grease System

Medium-Pressure Grease Pump 15:1 Package No. 2078

Handles: NLGI #0 & #00 Greases
Fits Container Size: 35 lb. (16 kg)

CORELUBE (A-1600) GREASE APPLICATOR

General Component Configuration:

The **A-1600 Housing** is machined from solid aluminum, not a casting, making it considerably stronger. This gives it the ability to withstand high internal pressures.

The replaceable seals and wear bushings snap easily into the housing. There are no tools, bolts, nuts or clamps needed to install or remove the seals or bushings.

Seal & Bushing sizes available:

1/4" (12mm) --- 2 1/2" (64mm)

Wear Bushing Data:

The hard rubber wear bushings extend the seal life by removing abrasives and centralizes the cable prior to contact with the softer seal.

Note: Only one bushing at the leading end of the housing is normally required.

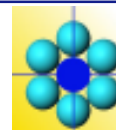
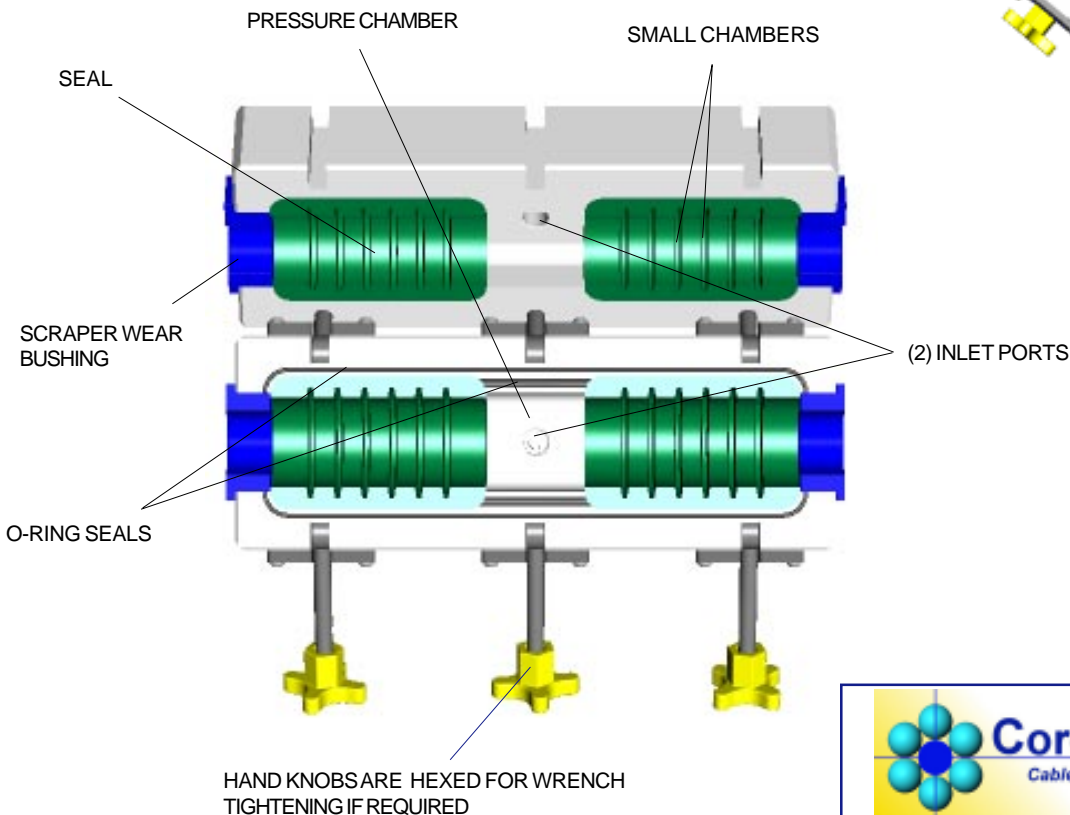
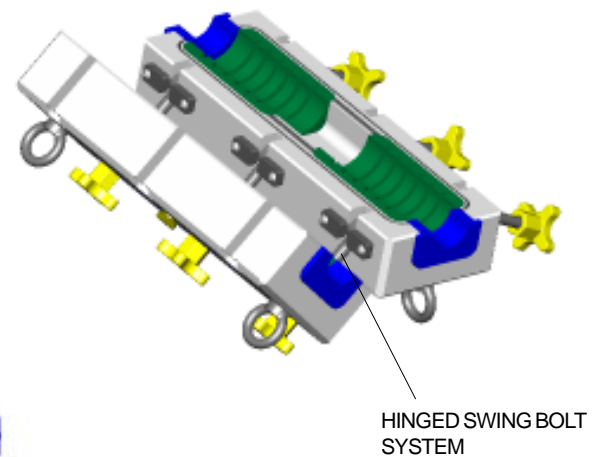
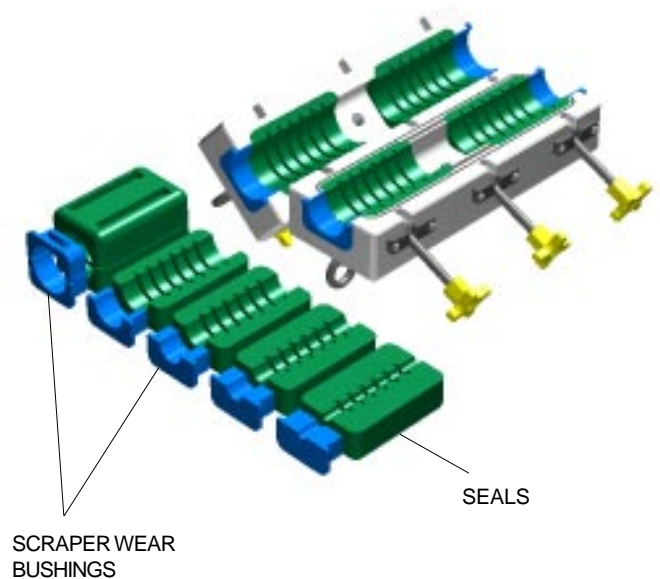

CoreLube Equipment

Cable Lubrication & Cleaning Specialist
division of B&C WireLine Ltd.

Phone: 403-529-9645 Fax: 403-527-1369

E-mail: sales@corelube.com

WWW.CORELUBE.COM